

AB1S THRU AB7S



SINGLE PHASE 1.0 AMP SURFACE MOUNT BRIDGE RECTIFIERS



FEATURES

- * Ideal for printed circuit board
- * Reliable low cost construction utilizing molded plastic technique
- * High surge current capability
- * Polarity: Symbol molded on body
- * Mounting position: Any

VOLTAGE RANGE

50 to 1000 Volts

CURRENT

1.0 Ampere

ABS

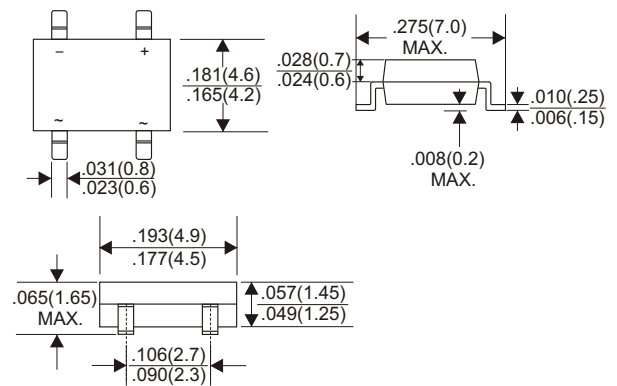

Dimensions in inches and (millimeters)

MAXIMUM RATINGS AND ELECTRICAL CHARACTERISTICS

Rating 25°C ambient temperature unless otherwise specified.
Single phase half wave, 60Hz, resistive or inductive load.
For capacitive load, derate current by 20%.

TYPE NUMBER	AB1S	AB2S	AB3S	AB4S	AB5S	AB6S	AB7S	UNITS
Maximum Recurrent Peak Reverse Voltage	50	100	200	400	600	800	1000	V
Maximum RMS Voltage	35	70	140	280	420	560	700	V
Maximum DC Blocking Voltage	50	100	200	400	600	800	1000	V
Maximum Average Forward Rectified Current								
at Ta=40°C	- on glass-epoxy P.C.B. (Note 1)			0.5				A
	- on aluminum substrate (Note 2)			1.0				A
Peak Forward Surge Current, 8.3 ms single half sine-wave superimposed on rated load (JEDEC method)				30				A
Maximum Forward Voltage Drop per Bridge Element at 0.5A D.C.				1.0				V
Maximum DC Reverse Current				5.0				μA
at Rated DC Blocking Voltage				500				μA
Typical Thermal Resistance RθJA (Note 3)				75				°C/W
Operating Temperature Range, Tj				-55 — +150				°C
Storage Temperature Range, Tsr				-55 — +150				°C

- NOTES: 1. On glass-epoxy P.C.B. mounted on 0.05 X 0.05" (1.27 X 1.27mm) soldering pads.
2. On aluminum substrate P.C.B. with an area of 0.8 X 0.8 X 0.25" (20 X 20 X 6.4mm) mounted on 0.05 X 0.05" (1.27 X 1.27mm) soldering pads.
3. Thermal Resistance Junction to Ambient.

RATING AND CHARACTERISTIC CURVES (AB1S THRU AB7S)

FIG.1-TYPICAL FORWARD CURRENT DERATING CURVE

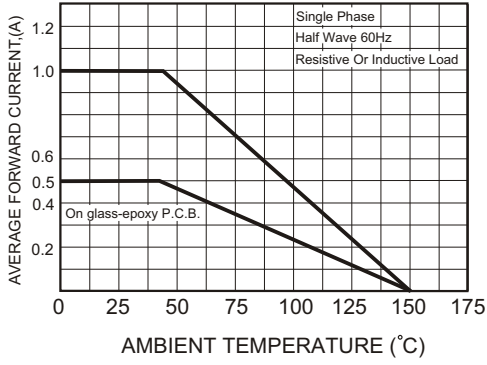

FIG.2-MAXIMUM NON-REPETITIVE FORWARD SURGE CURRENT

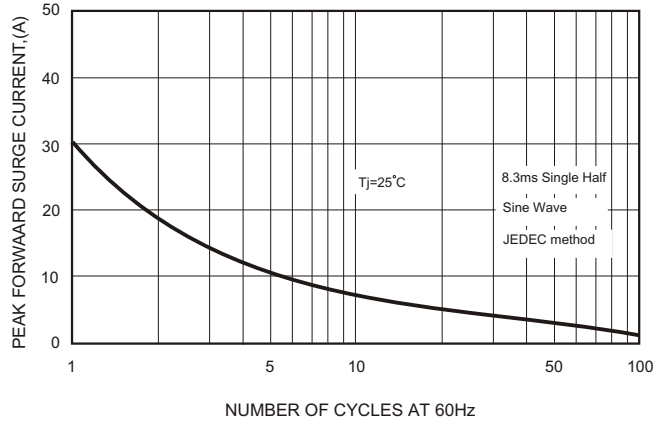

FIG.3-TYPICAL FORWARD CHARACTERISTICS

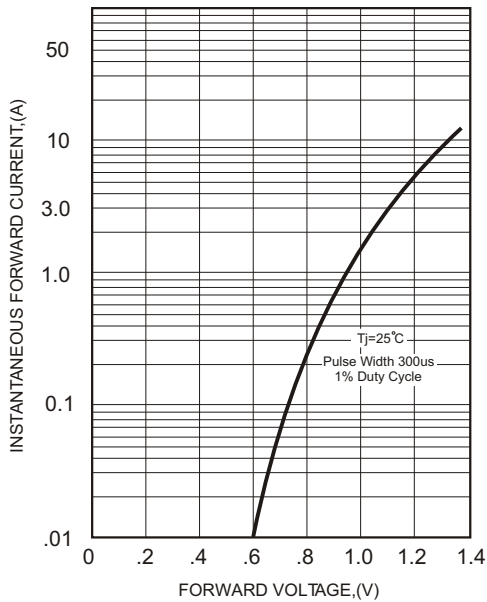

FIG.4-TYPICAL REVERSE CHARACTERISTICS

